

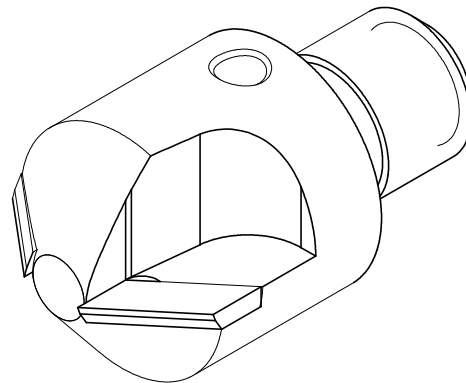

PCD 2fl Countersink Interchangeable Pilot (mm)

Body Diameter (+/-0.76)	Pilot Hole (+0.025)	CSK Angle (+/- 0.5)	Thread shank	cat# 100°	cat# 130°
10	2.50	100/130	M6x1.0	CRP1310250	CRP1510250
12	3.00	100/130	M6x1.0	CRP1312300	CRP1512300
14	3.00	100/130	M8x1.0	CRP1314300	CRP1514300
17	3.00	100/130	M8x1.0	CRP1317300	CRP1517300
19	4.00	100/130	M8x1.0	CRP1319400	CRP1519400
21	4.00	100/130	M8x1.0	CRP1321400	CRP1521400

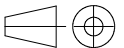

PCD C'sink Interchangeable Pilot		
Materials:	SCALE: NTS	This drawing is The property of TELCON DIAMOND And may only be Copied or passed To a third party With our permission.
Steel ; PCD		
CAT. NO.	Unless specified Tolerances are in Accordance with: DIN ISO 2768-m	
By Table		