

PCD BN End-mill (Inch)

Cutting Diameter (-.002)	Shank Diameter (h6)	LOC (min)	OAL (+.06)	# of flutes	Cat#
1/8	1/8	1/4	2	1	BOPM125125I
3/16	3/16	5/16	2	1	BOPM188188I
1/4	1/4	3/8	2	2	BOPM250250I
3/8	3/8	1/2	2.5	2	BOPM375375I
1/2	1/2	5/8	3	2	BOPM500500I
5/8	5/8	3/4	3.25	3	BOPM625625I

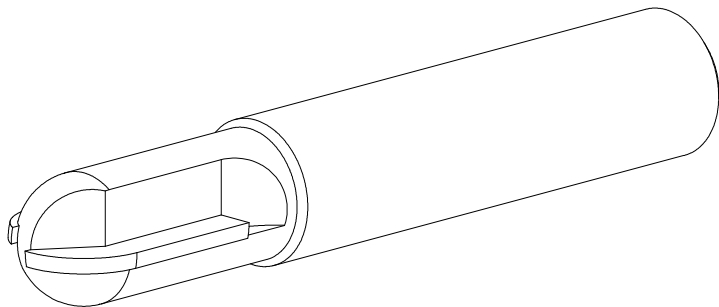

PCD BN EndMill		
Materials:	SCALE: NTS	<p>This drawing is The property of TELCON DIAMOND And may only be Copied or passed To a third party With our permission.</p>
Carbide ; PCD		
CAT. NO.	Unless specified Tolerances are in Accordance with: DIN ISO 2768-m	
By Table		