

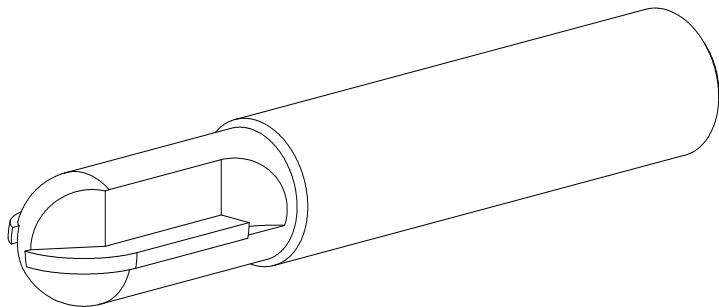

PCD BN End-mill (mm)

Cutting Diameter (-0.05)	Shank Diameter (h6)	LOC (+0.8)	OAL (+1.5)	# of flutes	Cat#
3	3.00	6	60	1	BOPM003003M
4	4.00	6	60	1	BOPM004004M
6	6.00	10	70	2	BOPM006006M
8	8.00	15	70	2	BOPM008008M
10	10.00	15	75	2	BOPM010010M
12	12.00	18	75	2	BOPM012012M
16	16.00	20	75	3	BOPM016016M

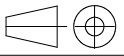

PCD BN EndMill	TELCON 	
Materials:	SCALE: NTS	<p>This drawing is The property of TELCON DIAMOND And may only be Copied or passed To a third party With our permission.</p>
Carbide ; PCD		
CAT. NO.	Unless specified Tolerances are in Accordance with: DIN ISO 2768-m	
By Table		