

PCD Multiflue End-mill (Inch)

Cutting Diameter (-.002)	Shank Diameter (h6)	LOC (min)	OAL (+.06)	# of flutes	Cat#
3/16	3/16	1/4	2.375	3	MOPM1881883I
5/16	5/16	7/16	2.375	3	MOPM3133133I
3/8	3/8	1/2	2.5	3	MOPM3753753I
3/8	3/8	1/3	2.5	5	MOPM3753755I
1/2	1/2	1/2	3	3	MOPM5005003I
1/2	1/2	1/2	3	5	MOPM5005005I
1/2	1/2	1/2	3	7	MOPM5005007I
1/2	1/2	1/2	3	9	MOPM5005009I
5/8	5/8	5/8	3.125	3	MOPM6256253I
5/8	5/8	5/8	3.125	5	MOPM6256255I
5/8	5/8	5/8	3.125	7	MOPM6256257I
5/8	5/8	5/8	3.125	9	MOPM6256259I

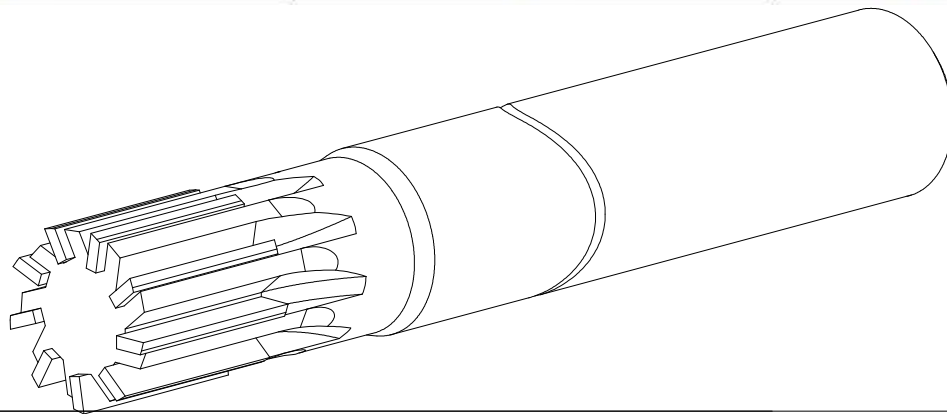

PCD EndMill
Multi Flute



Materials:

Carbide ; PCD

CAT. NO.

By Table

SCALE: NTS

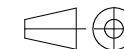

Unless specified
Tolerances are in
Accordance with:
DIN ISO 2768-m

This drawing is
The property of
TELCON DIAMOND
And may only be
Copied or passed
To a third party
With our permission.