

PCD Multiflute End-mill (mm)

Cutting Diameter (-0.05)	Shank Diameter (h6)	LOC (min)	OAL (+1.5)	# of flutes	Cat#
4	4.00	6	50	3	MOPM0040043M
6	6.00	6	60	3	MOPM0060063M
8	8.00	11	60	3	MOPM0080083M
10	10.00	13	63	3	MOPM0100103M
10	10.00	13	63	5	MOPM0100105M
12	12.00	13	75	3	MOPM0120123M
12	12.00	13	75	5	MOPM0120125M
12	12.00	13	75	7	MOPM0120127M
12	12.00	13	75	9	MOPM0120129M
16	16.00	16	79	3	MOPM0160163M
16	16.00	16	79	5	MOPM0160165M
16	16.00	16	79	7	MOPM0160167M
16	16.00	16	79	9	MOPM0160169M

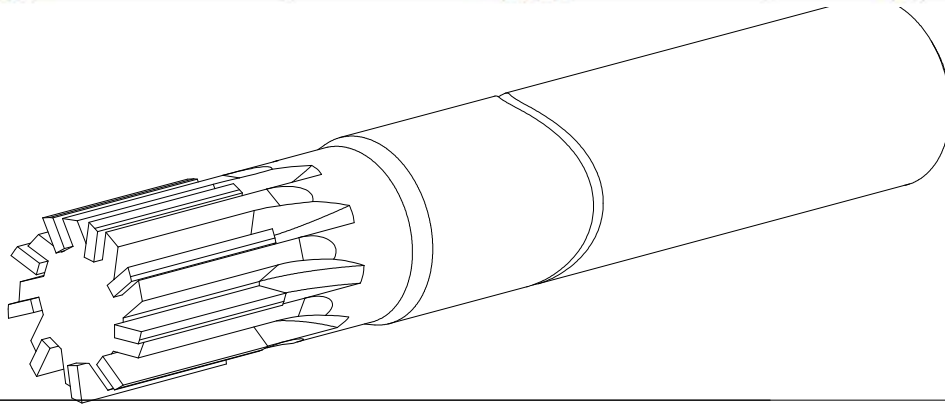

PCD EndMill
Multi Flute



Materials:

Carbide ; PCD

CAT. NO.

By Table

SCALE: NTS

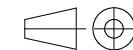

Unless specified
Tolerances are in
Accordance with:
DIN ISO 2768-m

This drawing is
The property of
TELCON DIAMOND
And may only be
Copied or passed
To a third party
With our permission.